

These drawings and specifications are the property of H2W Technologies, Inc. They are issued in confidence and shall not be reproduced, copied, or used without written permission from H2W Technologies, Inc.

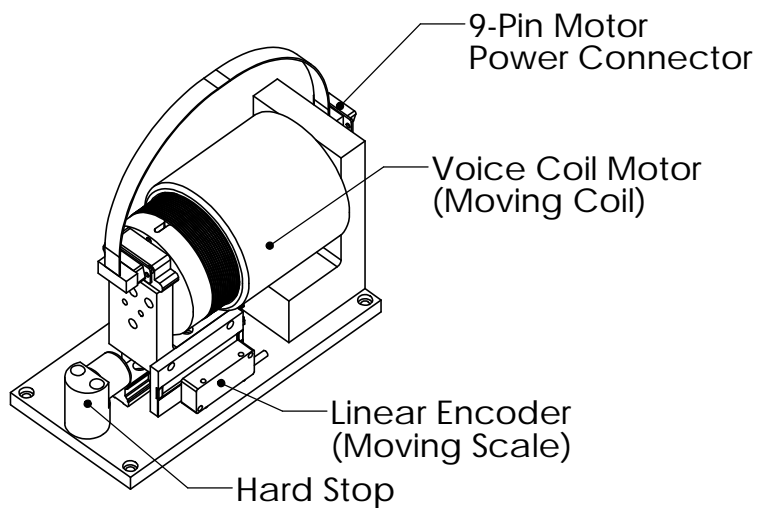
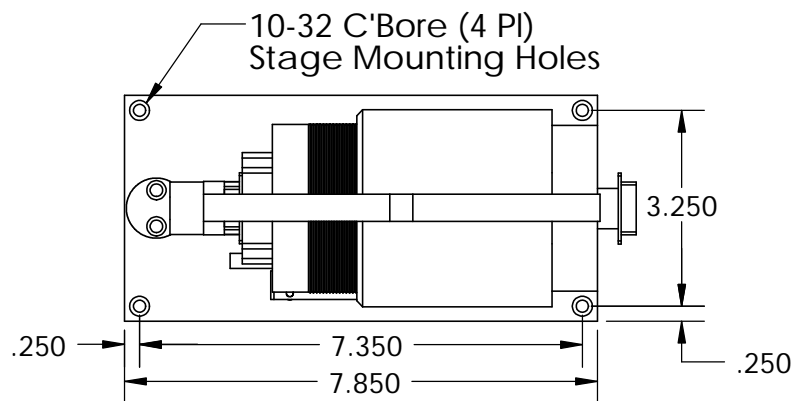
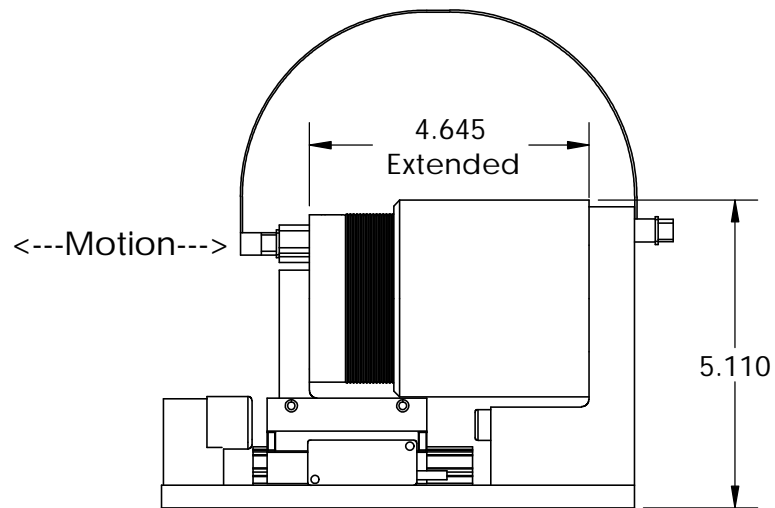
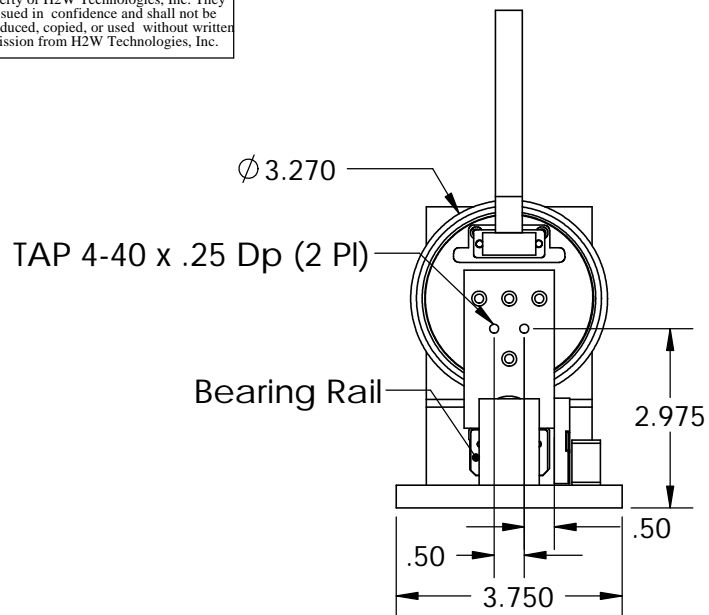

Stage Specifications		
Motor P/N	NCC08-32-225-1X	
Stroke	0.80"	
Force	22.5 lb	Cont.
	67.5 lb	Peak
Bearing Type	Linear Bearing	
Encoder Resolution	1 micron	

**H2W Technologies, Inc.**  
 28310-C Ave Crocker Valencia, CA 91355 USA  
 Tel: (661)-702-9346 Fax: (661)-702-9348  
 www.h2wtech.com

UNLESS SPECIFIED OTHERWISE:  
 All dimensions are in inches  
 Standard Tolerances are as follows  
 .XXX ±.005 ANGLES ±1°  
 .XX ±.010 FILLETS AND  
 .X ±.020 CORNERS .010  
 Remove All Burrs and Sharp Edges

MATERIAL				TITLE			
FINISH				VCS08-225-LB-01			
DRAWN OOG	DATE 11-21-02	APPROVED MPW	DATE 11-21-02	DWG #	30-0159	REV	A
						ECN	EC1192