

These drawings and specifications are the property of H2W Technologies, Inc. They are issued in confidence and shall not be reproduced, copied, or used without written permission from H2W Technologies, Inc. (www.h2wtech.com)

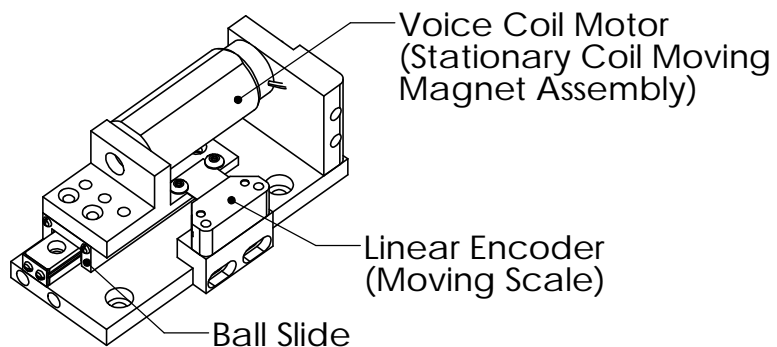
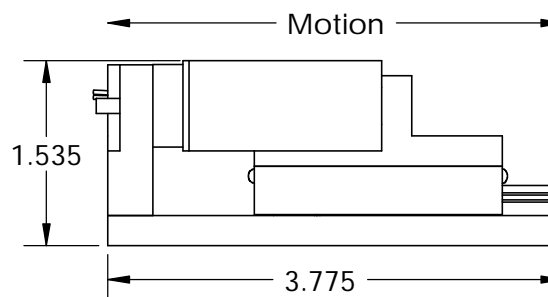
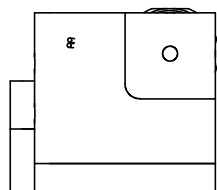
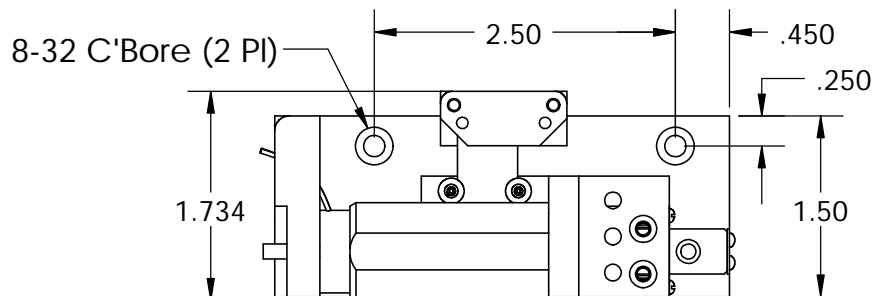

Stage Specifications		
Motor P/N	NCC06-08-005-2X	
Stroke	0.60"	
Force	0.5 lb	Cont.
	1.50 lb	Peak
Bearing Type	Ball Slide	
Encoder Resolution	12 micron	

**H2W Technologies, Inc.**  
 28310-C Ave Crocker Valencia, CA 91355 USA  
 Tel: (661)-702-9346 Fax: (661)-702-9348  
 www.h2wtech.com

UNLESS SPECIFIED OTHERWISE: All dimensions are in inches Standard Tolerances are as follows .XXX ±.005 ANGLES ±1° .XX ±.010 FILLETS .010 .X ±.020 CORNERS .010 Remove All Burrs and Sharp Edges				MATERIAL		TITLE	
FINISH				DRAWN		DWG #	
DATE				APPROVED		REV	
8-22-05				MPW		30-0426	
DATE				DATE		SHEET	
8-22-05				8-22-05		1 of 1	