

These drawings and specifications are the property of H2W Technologies, Inc. They are issued in confidence and shall not be reproduced, copied, or used without written permission from H2W Technologies, Inc. (www.h2wtech.com)

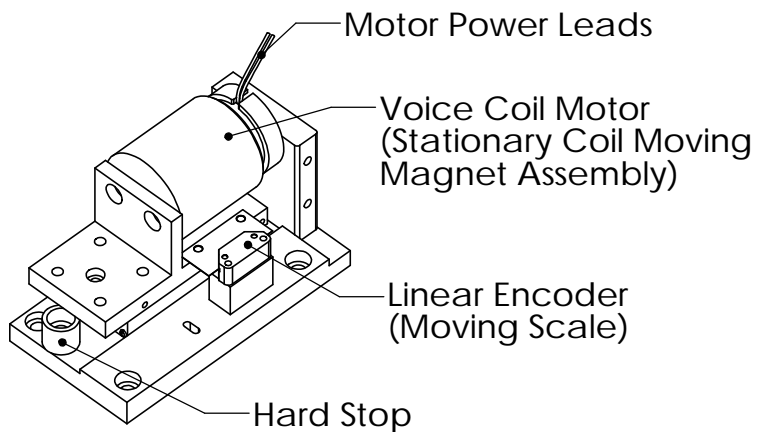
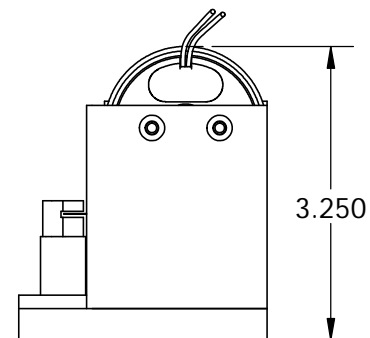
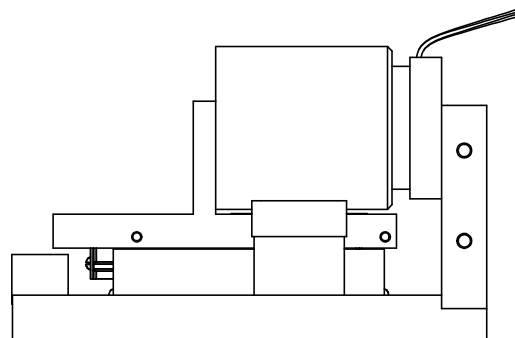
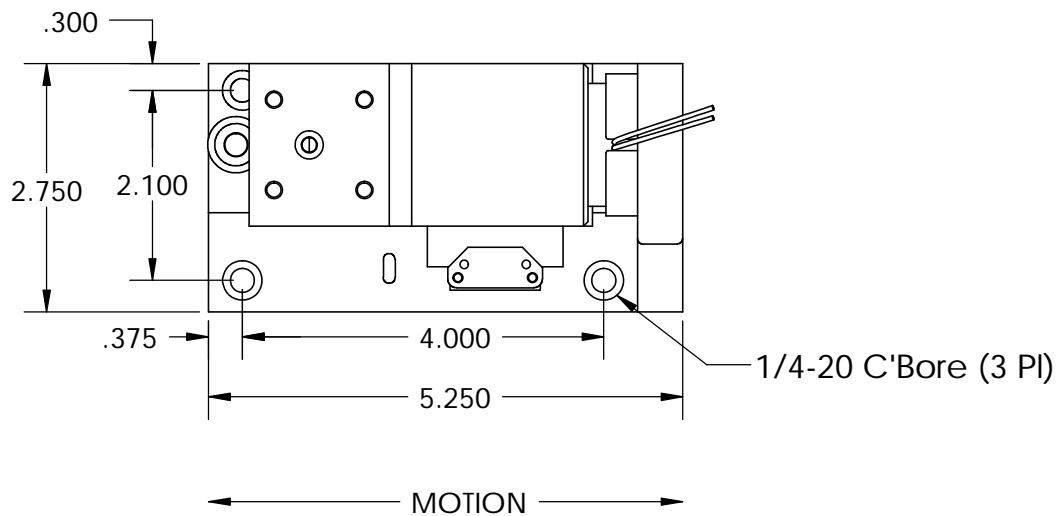

Stage Specifications		
Motor P/N	NCC05-18-040-2X	
Stroke	0.50"	
Force	6.0 lb	Cont.
	18.0 lb	Peak
Bearing Type	Ball Slide	
Encoder Resolution	12 micron	

H2W Technologies, Inc.
 28310-C Ave Crocker Valencia, CA 91355 USA
 Tel: (661)-702-9346 Fax: (661)-702-9348
 www.h2wtech.com

UNLESS SPECIFIED OTHERWISE:
 All dimensions are in inches
 Standard Tolerances are as follows
 .XXX ±.005 ANGLES ±1°
 .XX ±.010 FILLETS .010
 X ±.020 CORNERS .010
 Remove All Burrs and Sharp Edges

MATERIAL			
FINISH			
DRAWN	DATE	APPROVED	DATE
OOG	7-31-06	MPW	7-31-06

TITLE			
VCS05-060-BS-12			
DWG #	REV	SHEET	
31-0023		1 of 1	