

These drawings and specifications are the property of H2W Technologies, Inc. They are issued in confidence and shall not be reproduced, copied, or used without written permission from H2W Technologies, Inc.

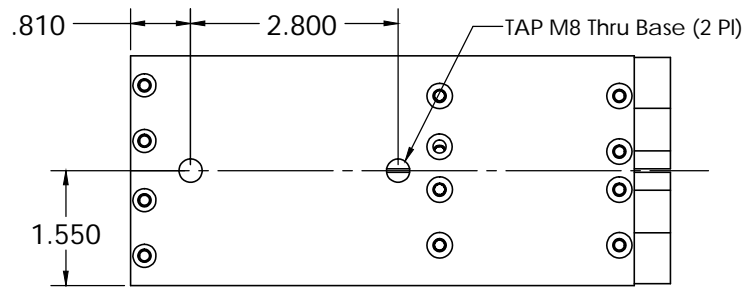
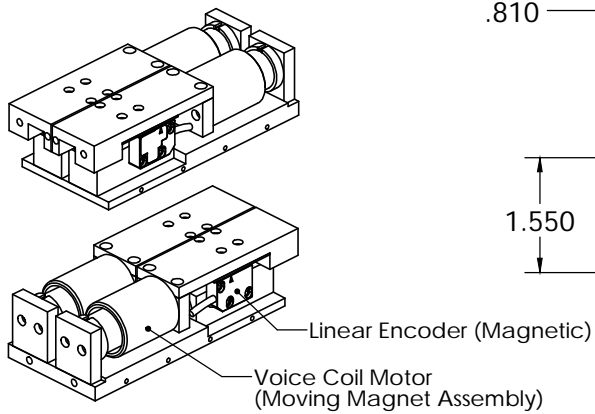
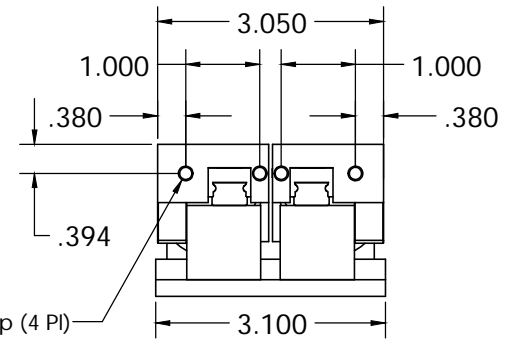
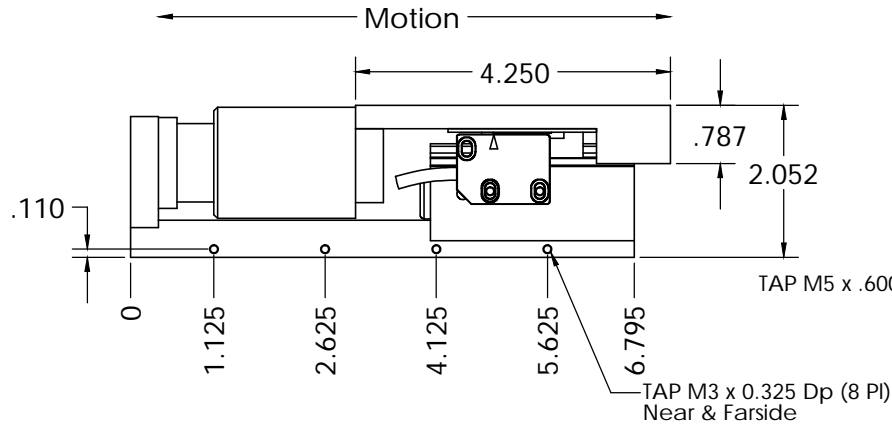
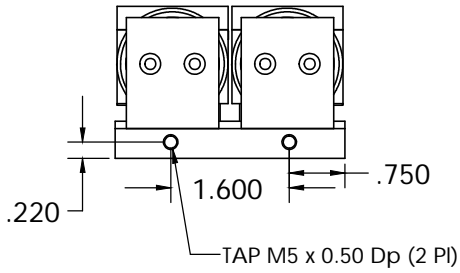
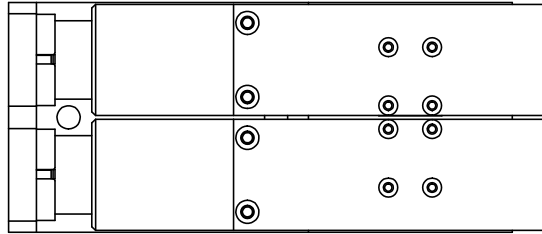

**Specs:**  
 Stroke = 1.0 in  
 Force (Cont) = 2.3 lbs  
 Force (Peak) = 6.9 lbs  
 Encoder = 1 micron

Motor P/N: NCC10-15-023-1X

**H2W Technologies, Inc.**  
 28310-C Ave Crocker Valencia, CA 91355 USA  
 Tel: (661)-702-9346 Fax: (661)-702-9348  
 www.h2wtech.com

UNLESS SPECIFIED OTHERWISE: All dimensions are in inches Standard Tolerances are as follows: XXX = .005 ANGLES ±1° XX = .010 FILLETS AND X = .020 CORNERS .010 Remove All Burs and Sharp Edges.		MATERIAL		TITLE	
FINISH		Anodize Blue		VCS10-023-LB-01-MD	
DRAWN	DATE	APPROVED	DATE	DWG #	REV
00G	11-11-08	MPW	11-11-08	31-0104	C
					SHEET
					1 of 1