

These drawings and specifications are the property of H2W Technologies, Inc. They are issued in confidence and shall not be reproduced, copied, or used without written permission from H2W Technologies, Inc. (www.h2wtech.com)

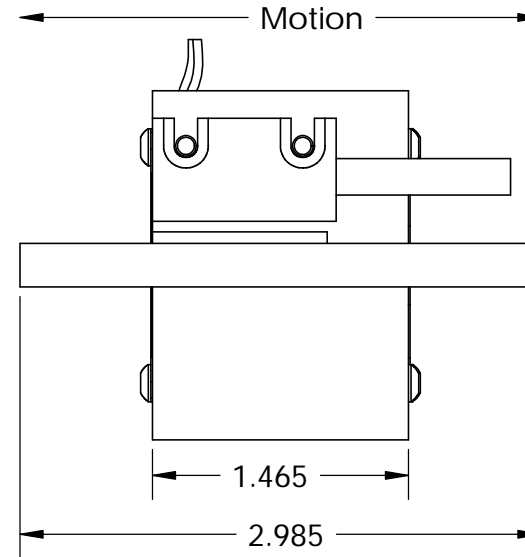
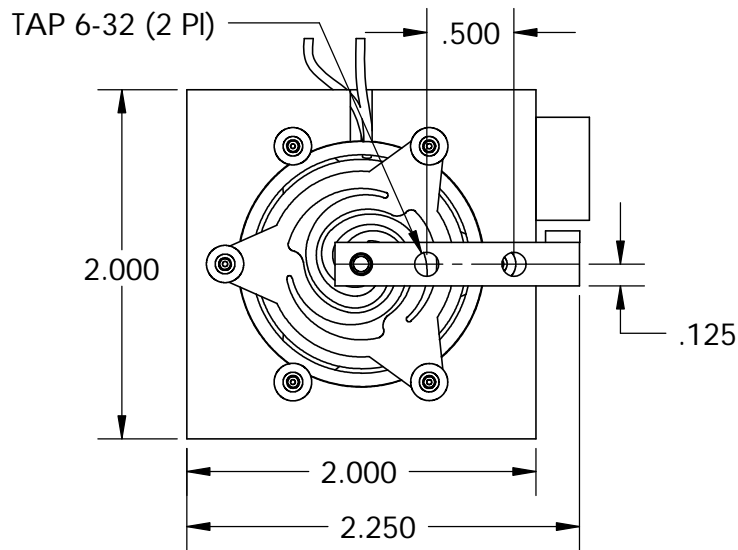

**Specs:**

Stroke = +/- 0.11 in  
 Force (Cont) = 3.5 lbs  
 Force (Peak) = 10.5 lbs  
 Encoder = 5 micron

Motor P/N: NCM02-17-035-2F

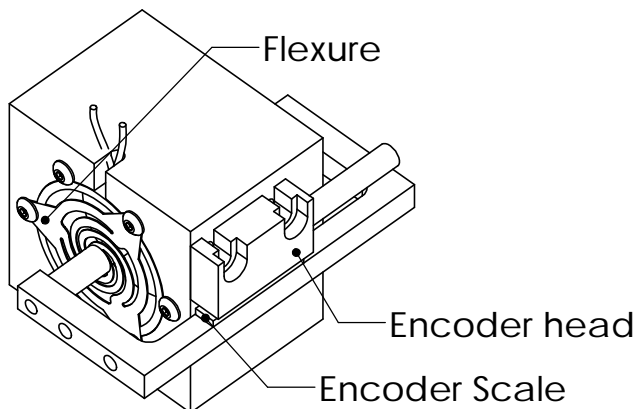
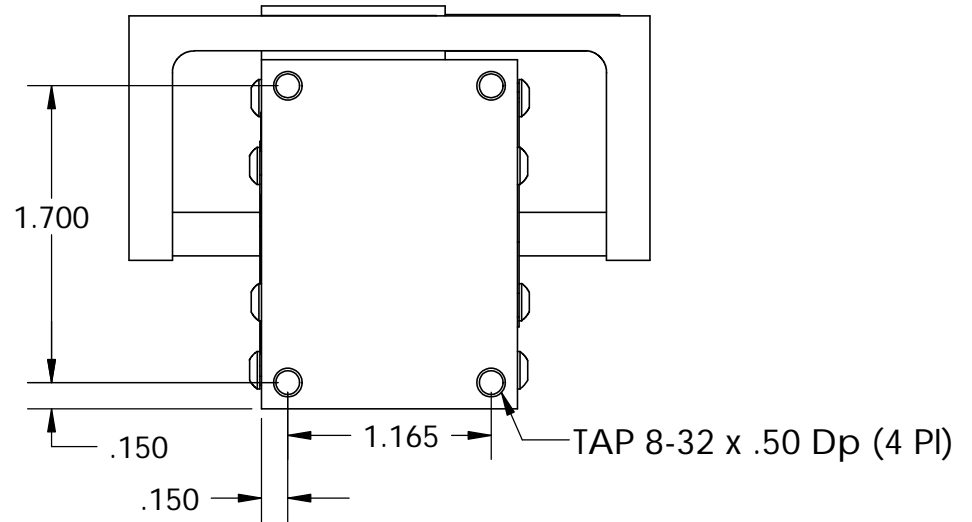

UNLESS SPECIFIED OTHERWISE:  
 All dimensions are in inches  
 Standard Tolerances are as follows  
 .XXX ±.005 ANGLES ±1°  
 .XX ±.010 FILLETS .010  
 .X ±.020 CORNERS .010  
 Remove All Burrs and Sharp Edges

MATERIAL			
FINISH			
DRAWN	DATE	APPROVED	DATE
OOG	6-27-08	MPW	6-27-08

TITLE			
VMS02-035-2F-05-M			
DWG #	REV	SHEET	
31-0077	A	1 of 1	

**H2W Technologies, Inc.**  
 28310-C Ave Crocker Valencia, CA 91355 USA  
 Tel: (661)-702-9346 Fax: (661)-702-9348  
 www.h2wtech.com