

These drawings and specifications are the property of H2W Technologies, Inc. They are issued in confidence and shall not be reproduced, copied, or used without written permission from H2W Technologies, Inc.

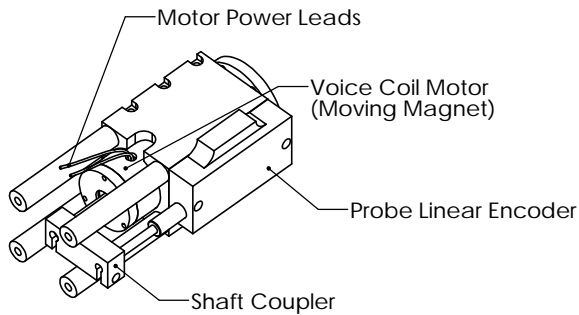
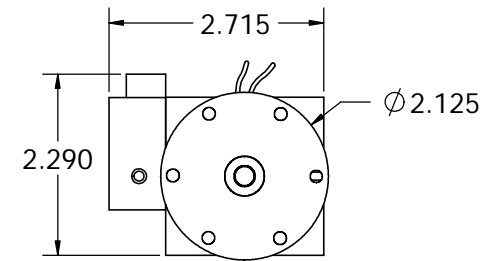
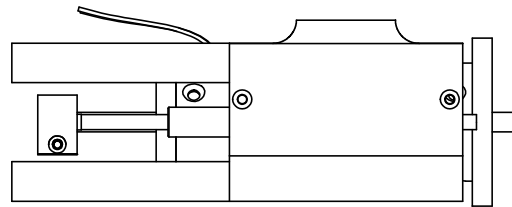
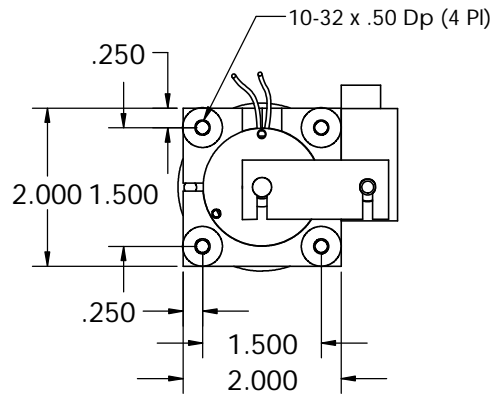
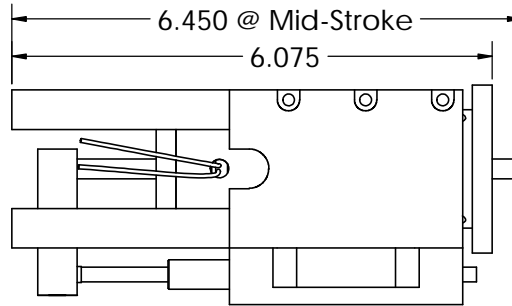

Stage Specifications	
Motor P/N	NCM10-15-020-2LB
Stroke	1.00"
Force	2.0 lb Cont. 6.0 lb Peak
Bearing Type	Linear Bushing
Encoder Resolution	12 micron

H2W Technologies, Inc.
28310-C Ave Crocker Valencia, CA 91355 USA
Tel: (661)-702-9346 Fax: (661)-702-9348
www.h2wtech.com

UNLESS SPECIFIED OTHERWISE: All dimensions are in inches Standard Tolerances are as follows: XXX ±.005 ANGLES ±1° XX ±.010 FILLETS AND X ±.020 CORNERS .010 Remove All Burs and Sharp Edges.		MATERIAL	FINISH		TITLE	
DRAWN	DATE	APPROVED	DATE	DWG #	REV	SHEET
OOG	10-16-06	MPW	10-16-06	30-0518	---	1 of 1