

These drawings and specifications are the property of H2W Technologies, Inc. They are issued in confidence and shall not be reproduced, copied, or used without written permission from H2W Technologies, Inc. (www.h2wtech.com)

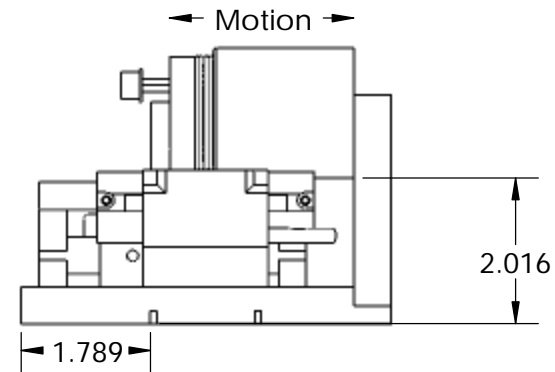

Total moving mass = 1.38 lb

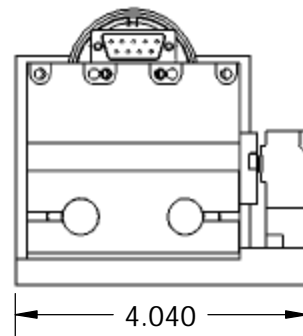
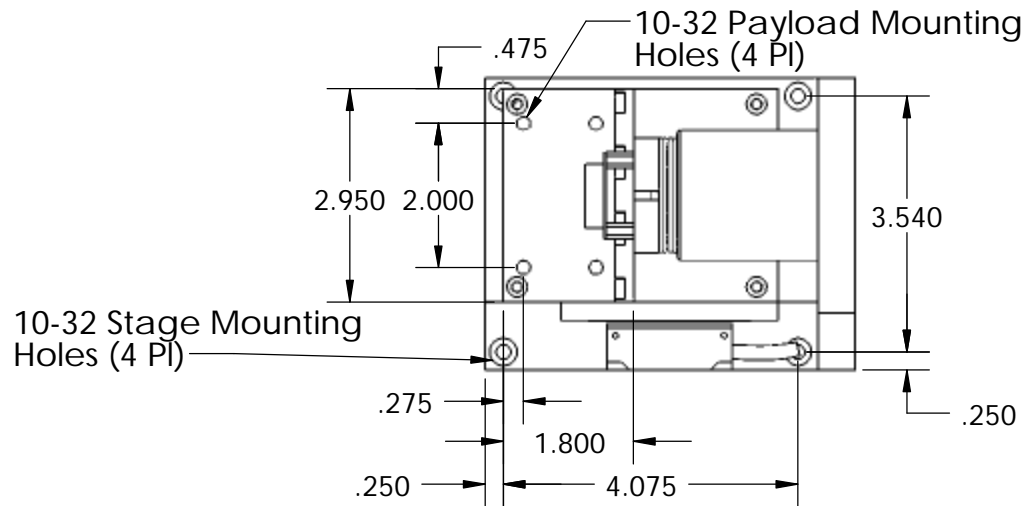
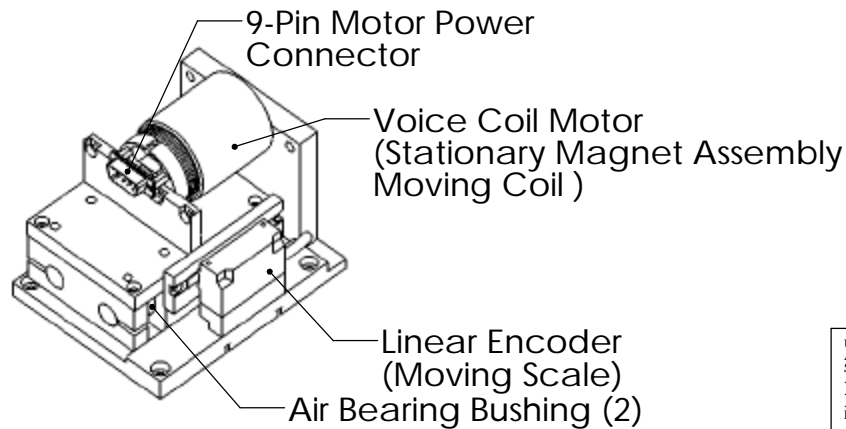

Stage Specifications		
Motor P/N	NCC05-16-060-2X	
Stroke	0.50"	
Force	6.0 lb	Cont.
	18.0 lb	Peak
Bearing Type	Air Bushing	
Encoder Resolution	1 micron	

**H2W Technologies, Inc.**  
 28310-C Ave Crocker Valencia, CA 91355 USA  
 Tel: (661)-702-9346 Fax: (661)-702-9348  
 www.h2wtech.com

UNLESS SPECIFIED OTHERWISE: All dimensions are in inches Standard Tolerances are as follows .XXX ±.005 ANGLES ±1° .XX ±.010 FILLETS .010 X ±.020 CORNERS .010 Remove All Burrs and Sharp Edges				MATERIAL		TITLE		
				FINISH		VCS05-060-AB-01		
DRAWN	DATE	APPROVED	DATE	DWG #	REV	SHEET		
OOG	12-5-06	MPW	12-5-06	31-0032	B	1 of 1		