

These drawings and specifications are the property of H2W Technologies, Inc. They are issued in confidence and shall not be reproduced, copied, or used without written permission from H2W Technologies, Inc. (www.h2wtech.com)

Specs:

Stroke = 0.50 in
 Force (Cont) = 6.0 lbs
 Force (Peak) = 18.0 lbs
 Encoder = 1 micron

Motor P/N: NCC05-18-060-2X

TAP 8-32 x .25 Dp (2 Pl)

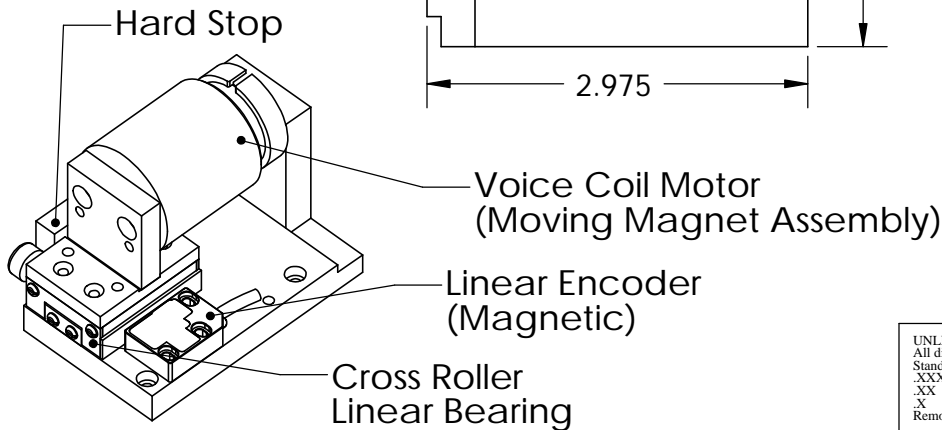
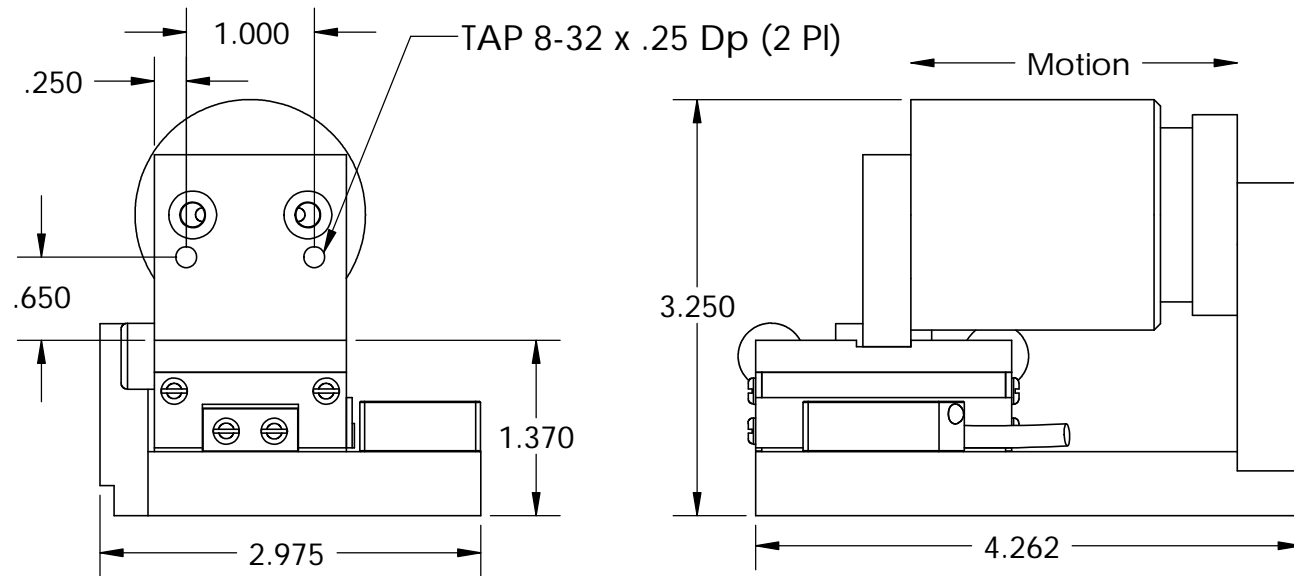
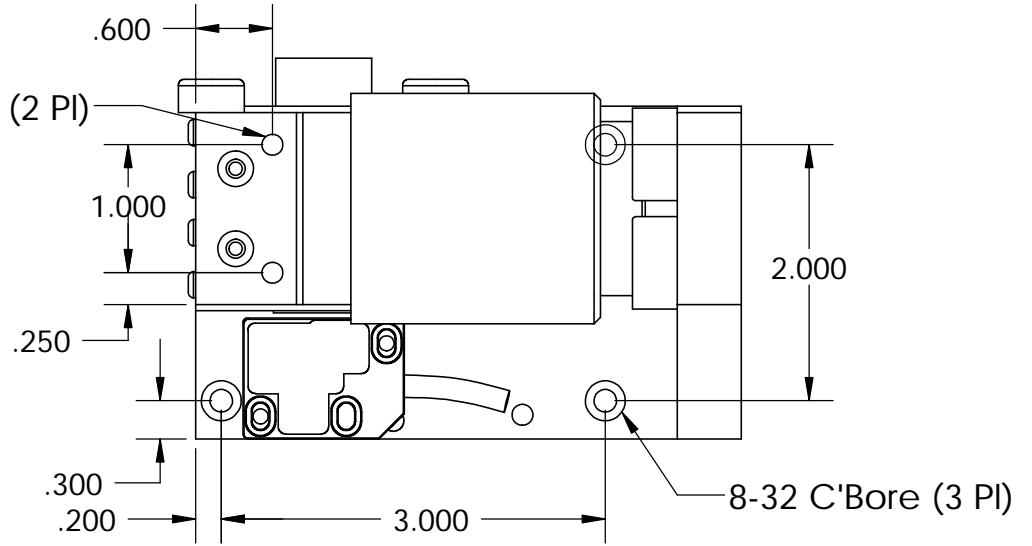

H2W Technologies, Inc.

28310-C Ave Crocker Valencia, CA 91355 USA
 Tel: (661)-702-9346 Fax: (661)-702-9348
 www.h2wtech.com

UNLESS SPECIFIED OTHERWISE:
 All dimensions are in inches
 Standard Tolerances are as follows:
 .XXX ±.005 ANGLES ±1°
 .XX ±.010 FILLETS .010
 .X ±.020 CORNERS .010
 Remove All Burrs and Sharp Edges

MATERIAL			
FINISH			
DRAWN OOG	DATE 10-13-08	APPROVED MPW	DATE 10-13-08

TITLE VCS05-060-CR-01-M			
DWG # 31-0116	REV ---	SHEET 1 of 1	