

These drawings and specifications are the property of H2W Technologies, Inc. They are issued in confidence and shall not be reproduced, copied, or used without written permission from H2W Technologies, Inc.

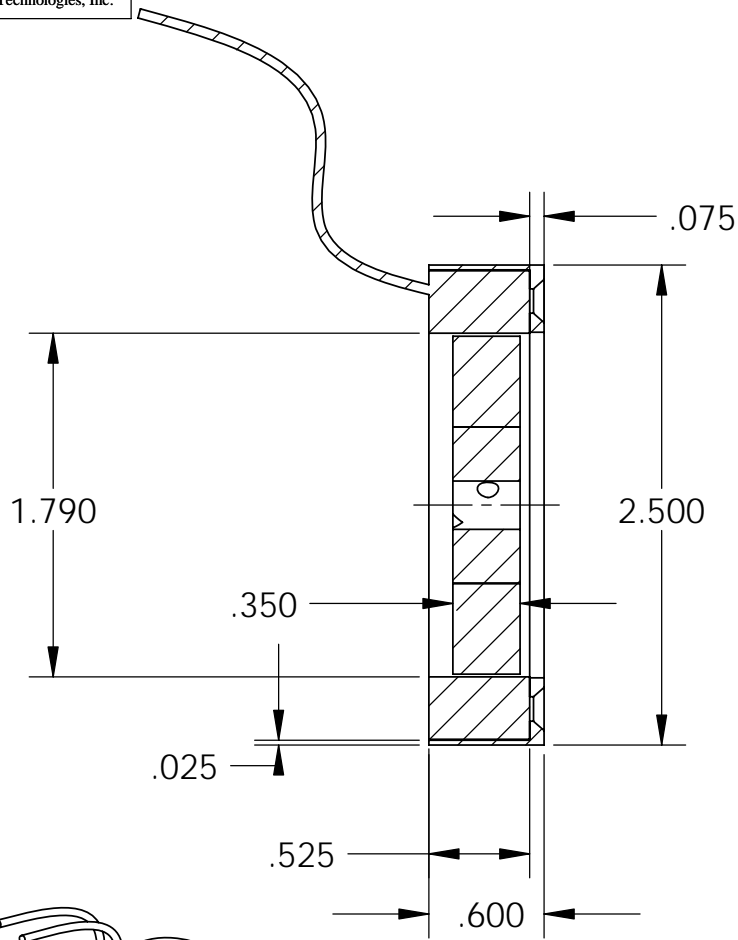

SECTION A-A

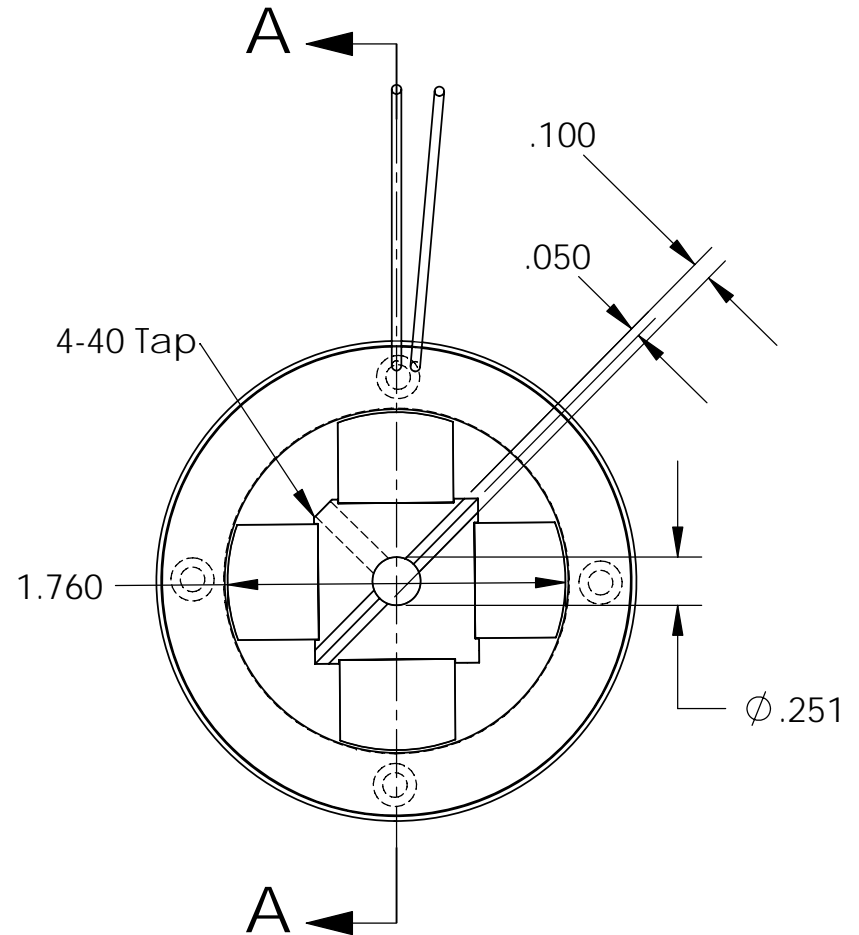
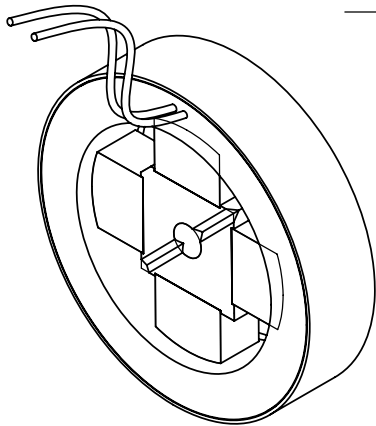

SPECIFICATIONS	
Model Number:	TMR-040-010-4
Constant Torque Angular Displacement:	40 degrees
Resistance:	4.2 ohms
Total Weight:	175 grams
Continuous Torque:	10 in-oz
Peak Torque:	30 in-oz
Motor Constant:	4.8 in-oz/sqrt(watts)

H2W Technologies, Inc.

28310-C Ave Crocker Valencia, CA 91355 USA
Tel: (661)-702-9346 Fax: (661)-702-9348
www.h2wtech.com

UNLESS SPECIFIED OTHERWISE:
All dimensions are in inches
Standard Tolerances are as follows:
.XXX ±.005 ANGLES ±1°
XX ±.010 FILLETS AND
X ±.020 CORNERS .010
Remove All Burrs and Sharp Edges

MATERIAL		FINISH		DATE	
-		-		04-02-03	
DRAWN	DATE	APPROVED	DATE		
JRM	04-02-03	MPW	04-02-03		

TITLE			
TMR-040-010-4			
DWG #	REV	ECN	
80-0061	---		