



February 16, 2004

Item Name: Eight Axis Vertical Gantry

Description: Eight axis vertical gantry for rapid pick and place applications

Specifications:

Horizontal X-axes

Dual Rail Linear Positioning Stages (DRS) with dual slide configuration Stage consists of an iron-core brushless linear motor, recirculating-ball linear bearings, 5-micron resolution non contact optical linear encoder, home and end of travel limit switches, hard stops, slides (2) and cable carriers (2) (one for each slide assembly). A unique characteristic of this design is that the structural elements and motion components have been combined to create a rigid self-supporting positioning stage.

Travel: 117 inches

Motor force: 27 lbs continuous, 81 lbs peak

Accuracy: +/- 50 microns/meter

Repeatability: +/- 2.5 microns

Max velocity: 120 inches/sec

Max acceleration: 4 G's

Vertical Y-Axes

Belt Drive Positioning Stage (BLS) is driven by a 3 phase brushless rotary motor with 4000 counts per rev. rotary encoder and an electrically operated brake for vertical operation. Stage enclosure is constructed of aluminum and houses the belt and pulley mechanisms, recirculating ball linear bearings, cable carrier, end of travel limit switches, and end of travel hard stops. The enclosure is designed to easily accept bellows for use in dirty environments.

Travel: 84 inches

Linear force: 50 lbs continuous, 150 peak

Accuracy: +/- 500 microns/meter

Repeatability: +/- 100 microns

Max velocity: 100 inches/sec

Max acceleration: 2 G's

Horizontal Z-Axes

Single Rail Linear Positioning Stage (SRS). 5.5 lb. continuous force, 16.5 lb. peak force. Stage consists of an ironless-core brushless linear motor, recirculating ball linear bearings, 5-micron resolution non-contact linear encoder, home and end of travel limit switches, hard stops, slide, and cable carrier.

Travel: 15 inches

Linear force: 50 lbs continuous, 150 peak

Accuracy: +/- 50 microns/meter

Repeatability: +/- 10 microns

Max velocity: 100 inches/sec

Max acceleration: 5 G's

Innovation in Linear Motion



Options: longer or shorter travel lengths, custom mounting holes, larger/smaller cable carriers, 1 and 0.1 micron resolution encoders, larger motors, enclosures, and bellows.

Benefits Summary: The vertical gantry design provides a stable and accurate motion platform for high-cycle pick and place applications. The linear motors offer almost maintenance-free operation and will not develop backlash problems associated with high-cycle use. The slim design of the gantry allows it to fit into tight spaces, this saving valuable floor space. The Gantry is completely modular allowing for easy assembly and disassembly.

Application: The vertical gantry design is a great solution for applications that require the coordinated motion of multiple axes. Typical applications are rapid pick and place, test and measurement, and other precise-placement applications requiring travel distances over a wide area.

Innovation in Linear Motion

28310-C Ave Crocker ▪ Valencia, CA 91355 ▪ USA ▪ 888.702.0540 ▪ 661.702.9346 ▪ 661.702.9348 Fax
www.h2wtech.com ▪ info@h2wtech.com

These drawings and specifications are the property of H2W Technologies, Inc. They are issued in confidence and shall not be reproduced, copied, or used without written permission from H2W Technologies, Inc. (www.h2wtech.com).

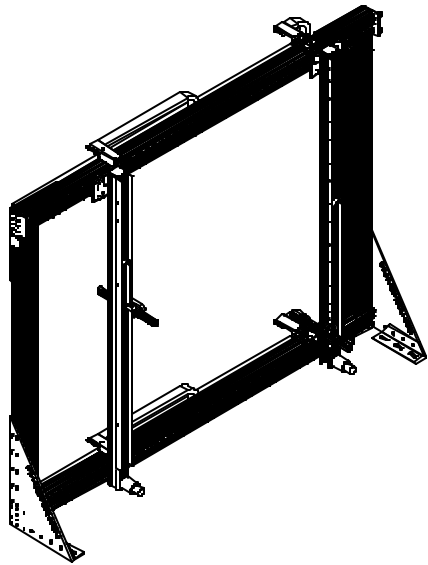
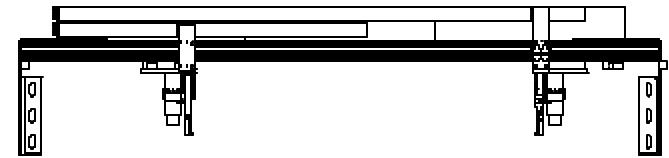
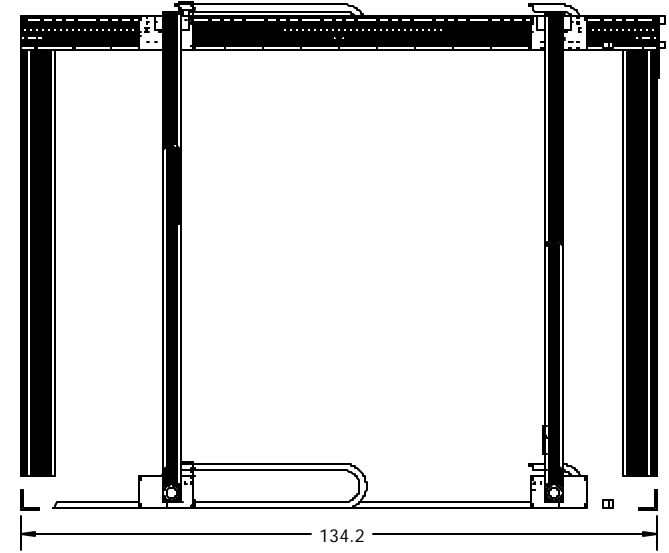
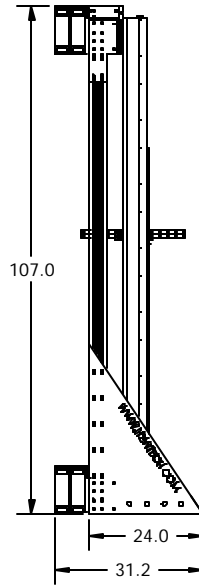
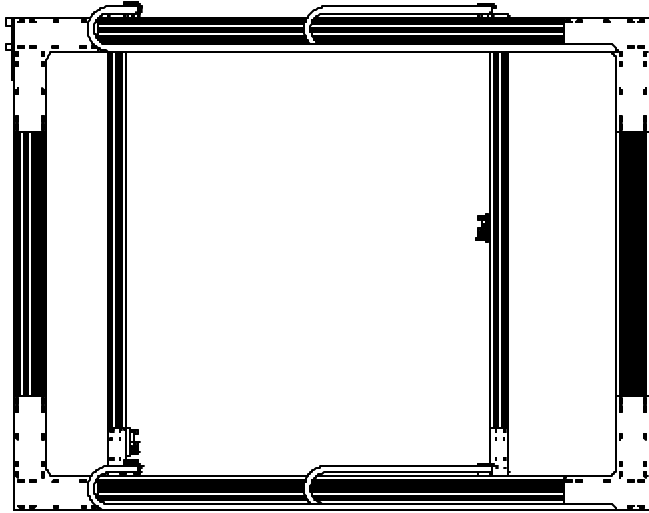

STROKE:
 X-AXIS = 111.00
 Y-AXIS = 80.00
 Z-AXIS = 15.20

H2W Technologies, Inc.

28310-C Ave Crocker Valencia, CA 91355 USA
 Tel: (661)-702-9346 Fax: (661)-702-9348
 www.h2wtech.com

UNLESS SPECIFIED OTHERWISE: ALL ARE DIMENSIONS IN INCHES XX.XX ANGLES 90° XX.XX R FILLETS .010 XX.XX R CORNERS .010 REMOVE ALL BURRS AND SHARP EDGES				MATERIAL				TITLE		
FINISH								8 Axis Gantry		
DRAWN	DATE	APPROVED	DATE	DWG #	REV	ECN				
DDG	6-4-03	MPW	6-4-03	40-0053	---	---				