

These drawings and specifications are the property of H2W Technologies, Inc. They are issued in confidence and shall not be reproduced, copied, or used without written permission from H2W Technologies, Inc. (www.h2wtech.com)

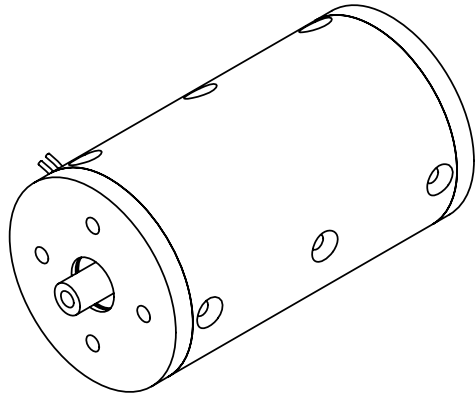
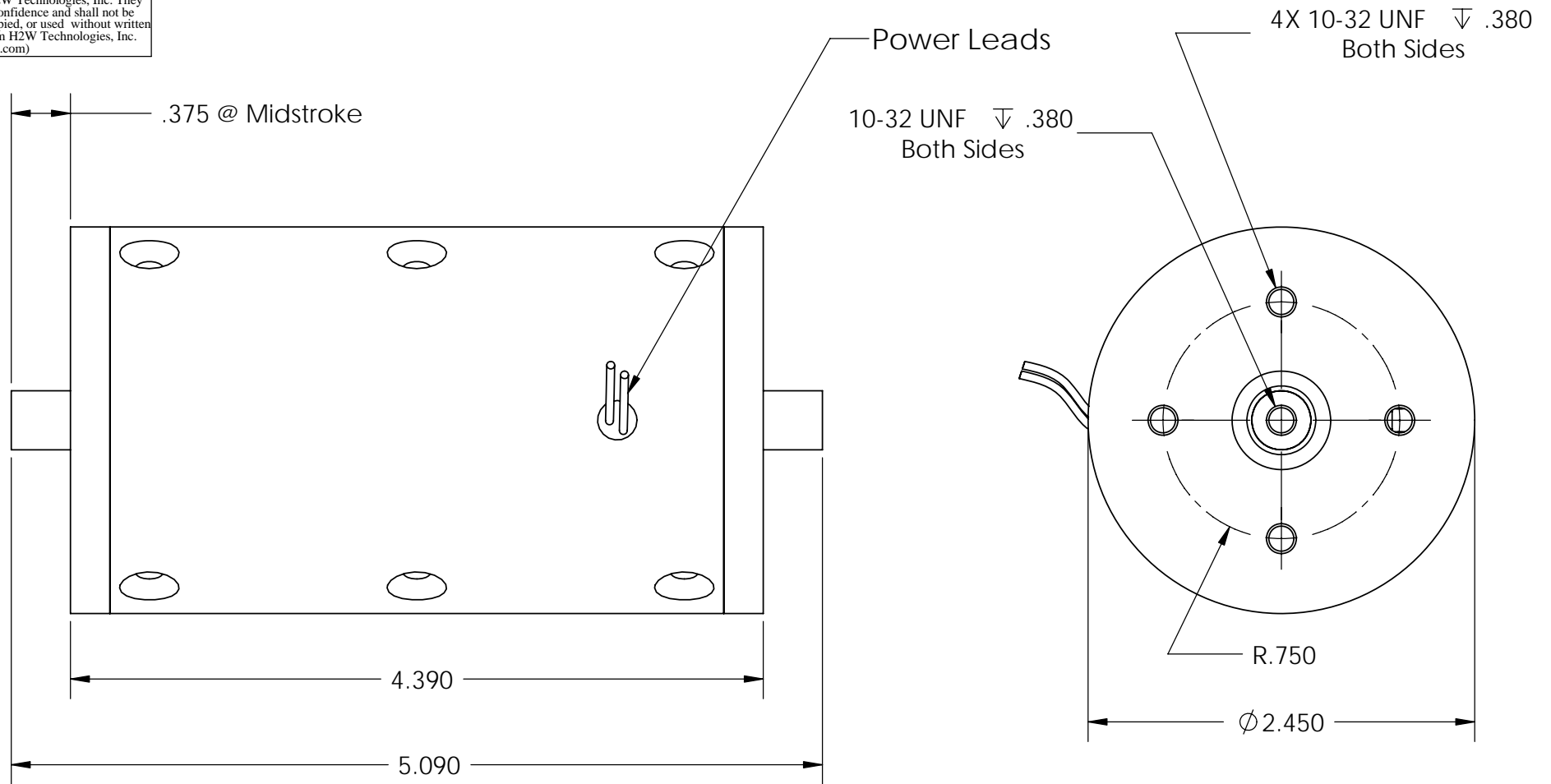

SPECIFICATIONS	
Motor P/N	NCM08-25-100-2LB
Stroke	0.75"
Bearing Type	Linear Bushing
Moving Mass	490 grams
Total Mass	1650 grams
Resistance	10.0 ohms
Force Constant	2.0 LBS/(Watt) ^{1/2}
Continuous Force	10.0 LBS
Peak Force	30.0 LBS
Power In @ 100% Duty	25 WATTS

H2W Technologies, Inc.
 28310-C Ave Crocker Valencia, CA 91355 USA
 Tel: (661)-702-9346 Fax: (661)-702-9348
 www.h2wtech.com

UNLESS SPECIFIED OTHERWISE: All dimensions are in inches Standard Tolerances are as follows .XXX ±.005 ANGLES ±1° XX ±.010 FILLETS .010 X ±.020 CORNERS .010 Remove All Burrs and Sharp Edges				MATERIAL			
				FINISH			
DRAWN	DATE	APPROVED	DATE	DRAWN	DATE	APPROVED	DATE
JRM	1-24-07	MPW	1-24-07				

TITLE			
NCM08-25-100-2LB			
DWG #	REV	SHEET	
30-0550	A	1 of 1	