

These drawings and specifications are the property of H2W Technologies, Inc. They are issued in confidence and shall not be reproduced, copied, or used without written permission from H2W Technologies, Inc. (www.h2wtech.com)

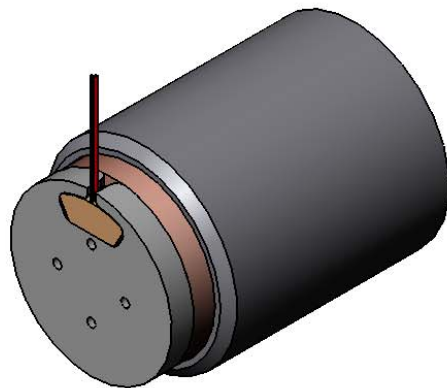
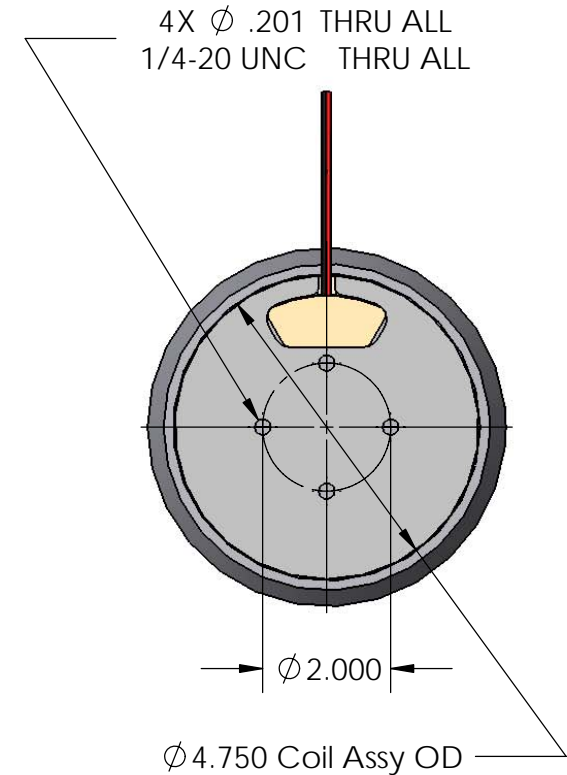
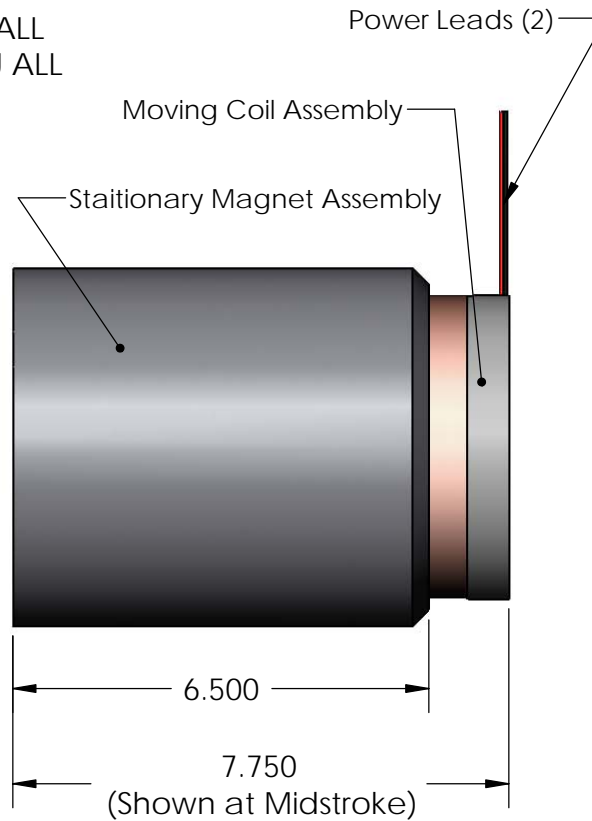
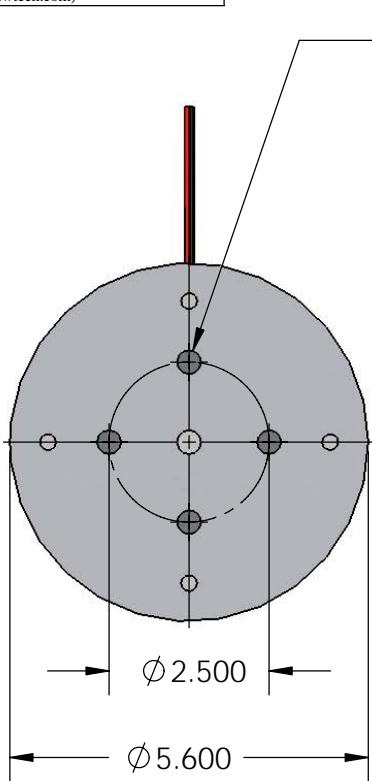

SPECIFICATIONS	
Motor P/N	NCC12-60-1000-2X
Stroke	1.20" [30.5 mm]
Radial Clearance	0.025" per side
Moving Mass	7 LBS
Total Mass	43 LBS
Resistance	3 ohms
Force Constant	10.0 LBS/(Watt) ^{1/2}
Continuous Force	100 LBS
Peak Force	300 LBS
Power In @ 100% Duty	100 WATTS
Power In @ 10% Duty	900 WATTS

H2W Technologies, Inc.

28310-C Ave Crocker Valencia, CA 91355 USA
Tel: (661)-702-9346 Fax: (661)-702-9348
www.h2wtech.com

UNLESS SPECIFIED OTHERWISE: All dimensions are in inches Standard Tolerances are as follows .XXX ±.005 ANGLES ±1° .XX ±.010 FILLETS .010 .X ±.020 CORNERS .010 Remove All Burrs and Sharp Edges				MATERIAL		TITLE	
				FINISH		NCC12-60-1000-2X	
DRAWN	DATE	APPROVED	DATE	DWG #	REV	SHEET	
JRM	4-26-06	MPW	4-26-06	30-0478		1 of 1	