

These drawings and specifications are the property of H2W Technologies, Inc. They are issued in confidence and shall not be reproduced, copied, or used without written permission from H2W Technologies, Inc.

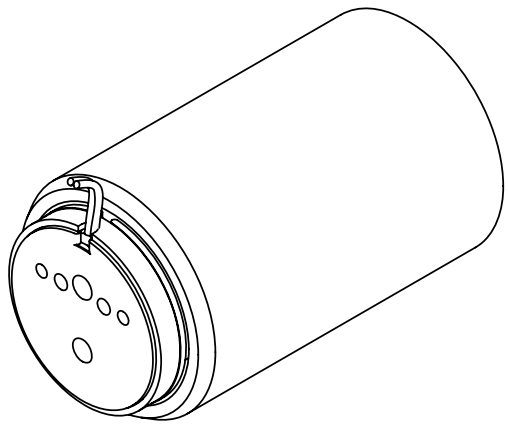
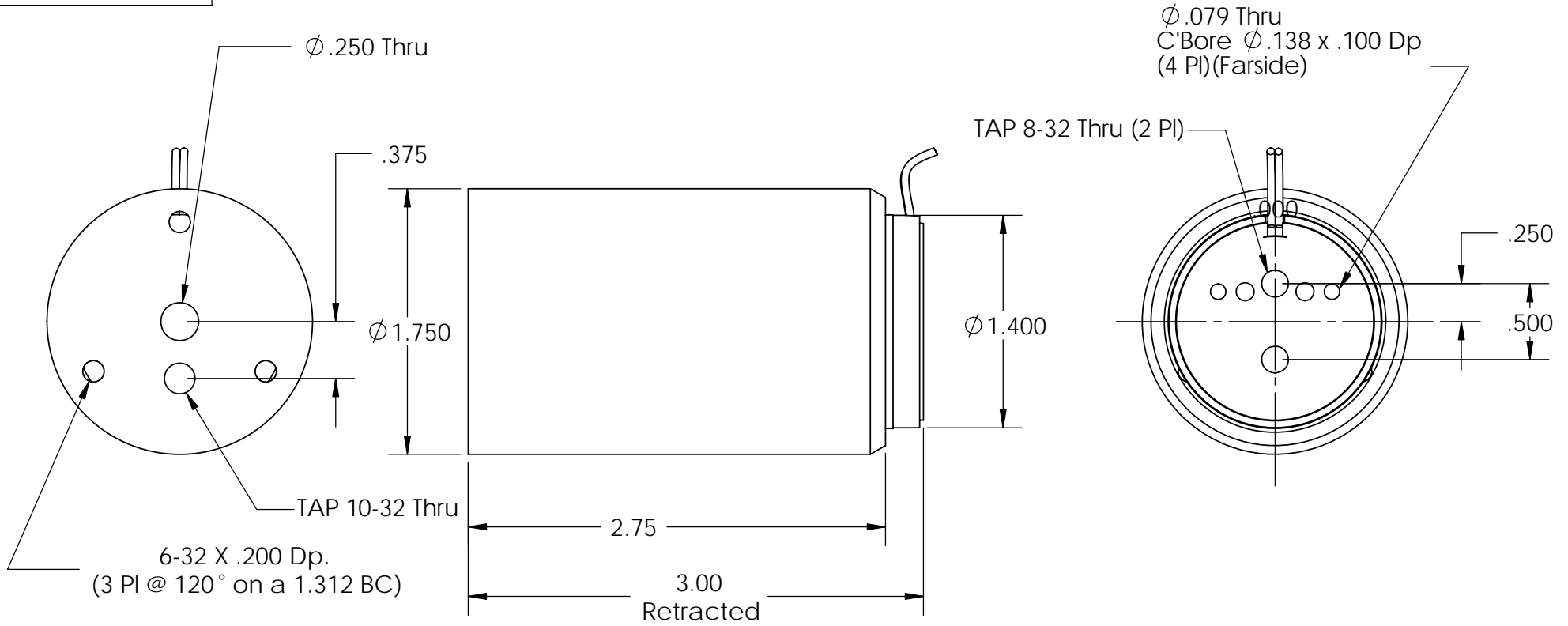

SPECIFICATIONS	
Motor P/N	NCC20-18-020-1X
Stroke	2.00"
Radial Clearance	0.025" per side
Moving Mass	16 grams
Total Mass	138 grams
Resistance	3.5 ohms
Force Constant	0.86 LBS/(Watt) ^{1/2}
Continuous Force	2.00 LBS
Peak Force	6.00 LBS
Power In @ 100% Duty	5 WATTS

H2W Technologies, Inc.
 28310-C Ave Crocker Valencia, CA 91355 USA
 Tel: (661)-702-9346 Fax: (661)-702-9348
 www.h2wtech.com

UNLESS SPECIFIED OTHERWISE: All dimensions are in inches Standard Tolerances are as follows .XXX ±.005 ANGLES ±1° .XX ±.010 FILLETS AND .X ±.020 CORNERS .010 Remove All Burrs and Sharp Edges	MATERIAL				TITLE		
	FINISH				NCC20-18-020-1X		
	DRAWN JRM	DATE 11-14-03	APPROVED MPW	DATE 11-14-03	DWG # 30-0260	REV A	ECN