

These drawings and specifications are the property of H2W Technologies, Inc. They are issued in confidence and shall not be reproduced, copied, or used without written permission from H2W Technologies, Inc.

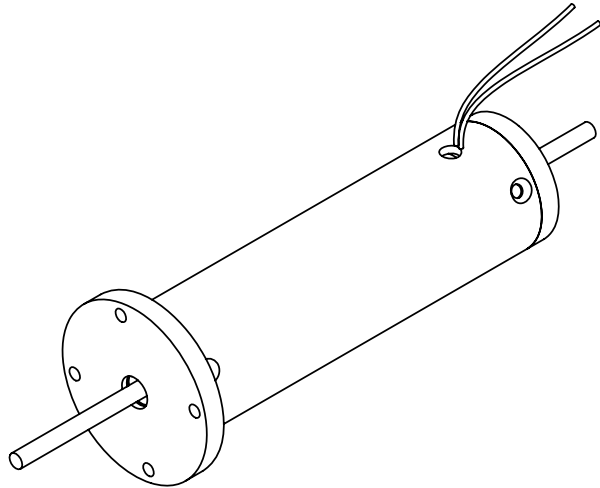
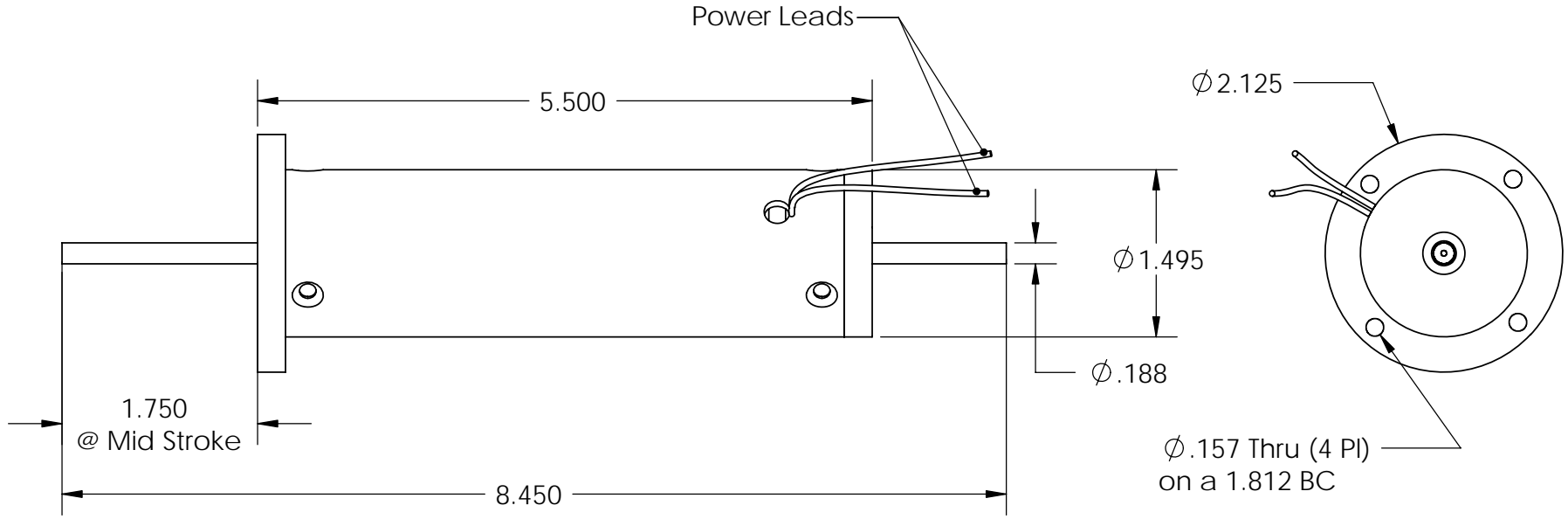

SPECIFICATIONS	
Motor P/N	NCM15-15-032-2LB
Stroke	1.50"
Bearing Type	Linear Bushing
Moving Mass	212 grams
Total Mass	545 grams
Resistance	5.0 ohms
Force Constant	0.80 LBS/(Watt) <sup>1/2</sup>
Continuous Force	3.20 LBS
Peak Force	9.60 LBS
Power In @ 100% Duty	16 WATTS

**H2W Technologies, Inc.**

28310-C Ave Crocker Valencia, CA 91355 USA  
 Tel: (661)-702-9346 Fax: (661)-702-9348  
 www.h2wtech.com

UNLESS SPECIFIED OTHERWISE:  
 All dimensions are in inches  
 Standard Tolerances are as follows  
 .XXX ±.005 ANGLES ±1°  
 .XX ±.010 FILLETS AND  
 .X ±.020 CORNERS .010  
 Remove All Burrs and Sharp Edges

MATERIAL			
FINISH			
DRAWN OOG	DATE 5-13-03	APPROVED MPW	DATE 5-13-03

TITLE			
NCM15-15-032-2LB Actuator			
DWG #	REV	ECN	
30-0215	A		