

These drawings and specifications are the property of H2W Technologies, Inc. They are issued in confidence and shall not be reproduced, copied, or used without written permission from H2W Technologies, Inc.

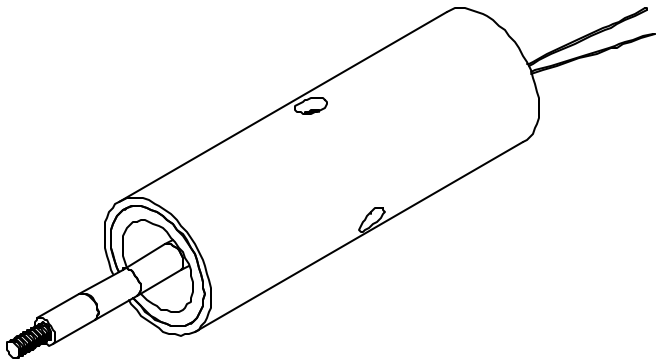
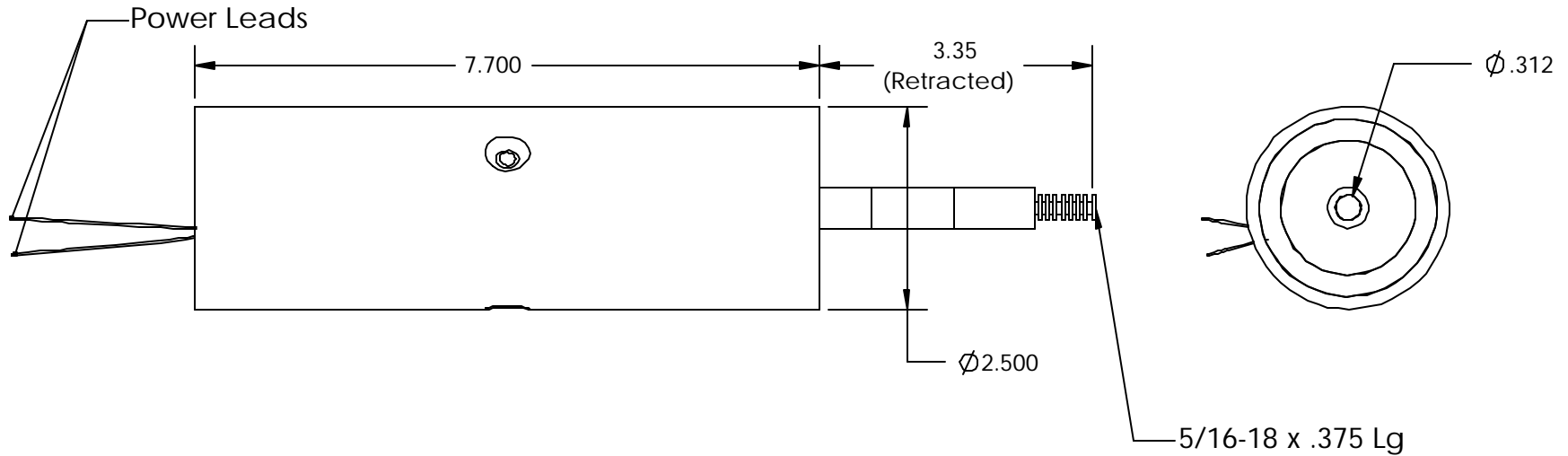

SPECIFICATIONS	
Motor P/N	NCM30-25-090-2X
Stroke	3.00"
Bearing Type	Delrin
Moving Mass	2.35 LBS
Total Mass	6.00 LBS
Resistance	0.7 W
Force Constant	1.16 LBS/(Watt) <sup>1/2</sup>
Continuous Force	9.00 LBS
Peak Force	27.0 LBS
Power In @ 100% Duty	70 WATTS

**H2W Technologies, Inc.**  
 28310-C Ave Crocker Valencia, CA 91355 USA  
 Tel: (661)-702-9346 Fax: (661)-702-9348  
 www.h2wtech.com

UNLESS SPECIFIED OTHERWISE: All dimensions are in inches Standard Tolerances are as follows .XXX ±.005 ANGLES ±1° .XX ±.010 FILLETS AND X ±.020 CORNERS .010 Remove All Burrs and Sharp Edges				MATERIAL		TITLE	
				FINISH		NCM30-25-090-2X	
DRAWN OOG	DATE 5-13-02	APPROVED FGW	DATE 5-13-02	DWG #	30-0102	REV	---
						ECN	