

These drawings and specifications are the property of H2W Technologies, Inc. They are issued in confidence and shall not be reproduced, copied, or used without written permission from H2W Technologies, Inc. (www.h2wtech.com)

| REVISION TABLE | | | | | |
|----------------|------|------------------|--------|----------|--------|
| REV | ECN# | DESCRIPTION | REV BY | APPROVED | DATE |
| --- | --- | Original Drawing | SDC | MPW | 7-7-15 |

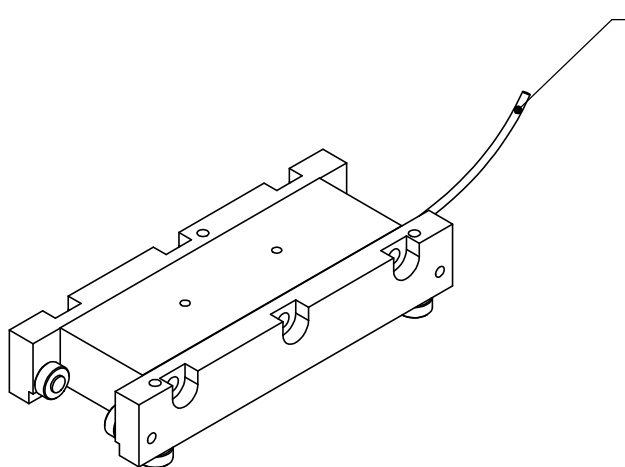
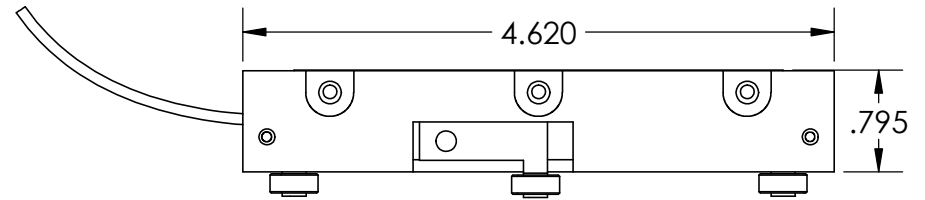
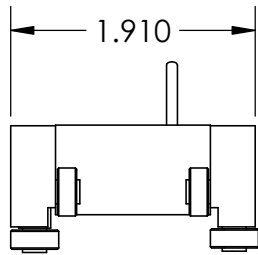
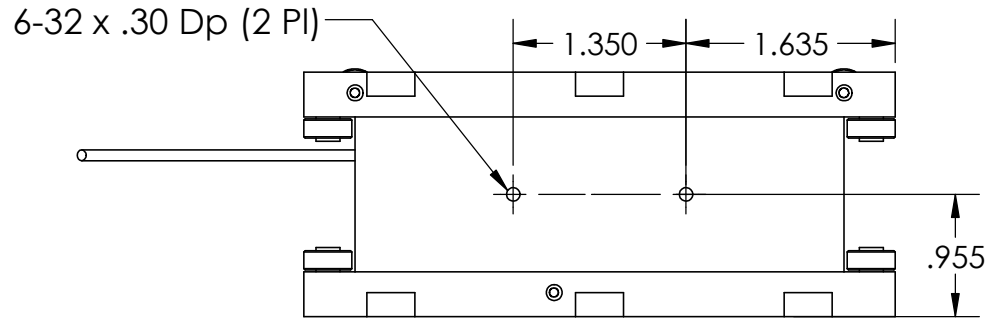

Motor Power Cable

| Lead Color | Function |
|------------|----------|
| Yellow | A+ |
| White | A- |
| Red | B+ |
| Black | B- |

10in Long
(standard length)

Forcer Model #LMSS0604-2WW0



H2W Technologies, Inc.
26380 Ferry Court Santa Clarita, CA 91350 USA
Tel: (661) 291-1620 Fax: (661) 291-1626
www.h2wtech.com

| | | | | | |
|--|--------|----------|--------|---------|-------|
| UNLESS SPECIFIED OTHERWISE: All dimensions are in inches Standard Tolerances are as follows .XXX ±.005 ANGLES ±1° .XX ±.010 FILLETS .010 .X ±.020 CORNERS .010 Remove All Burs and Sharp Edges | | MATERIAL | | TITLE | |
| FINISH | | DRAWN | | DWG # | |
| DATE | | APPROVED | | REV | |
| SDC | 7-7-15 | MPW | 7-7-15 | --- | SHEET |
| | | | | 10-0611 | |
| | | | | 1 of 4 | |

4lb Linear Stepper Motor

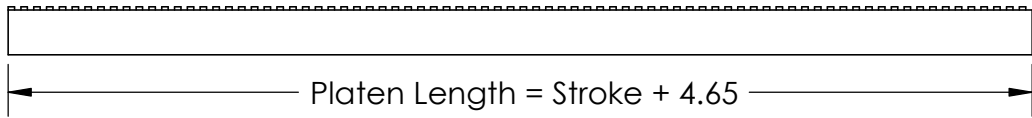
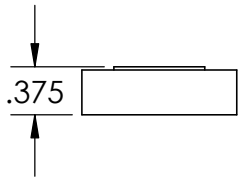
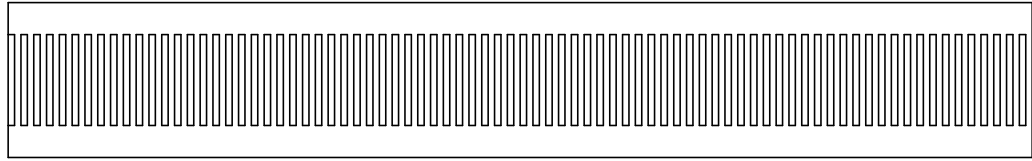

8-32 x .20 Dp

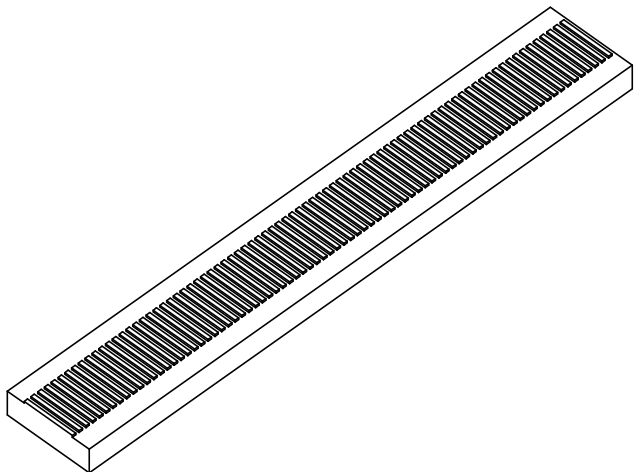
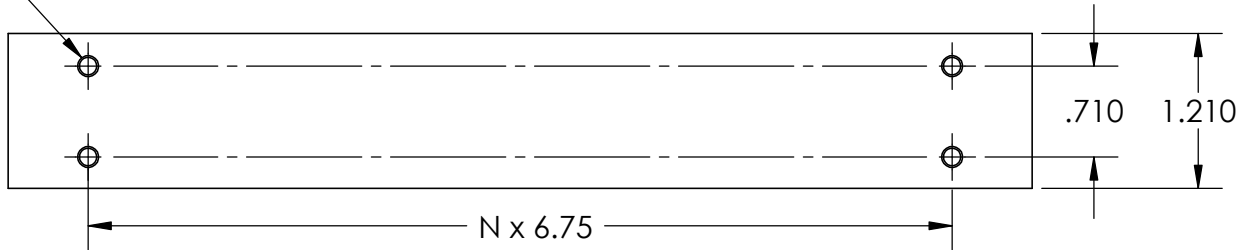

Platen Model # STP-13-XXX-R

TITLE
2lb Linear Stepper Motor

XXX = Platen Length in inches

DWG # **10-0611**

REV ---

SHEET
2 of 4

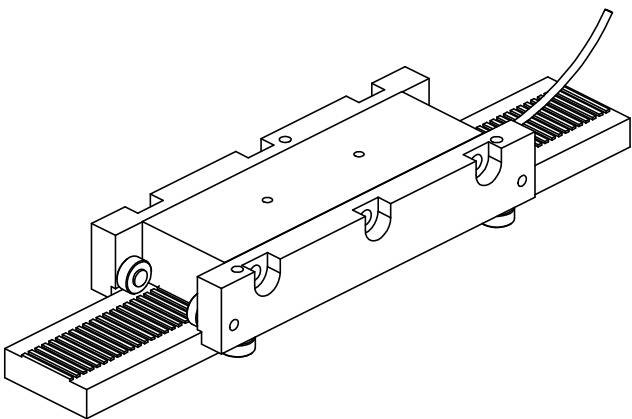
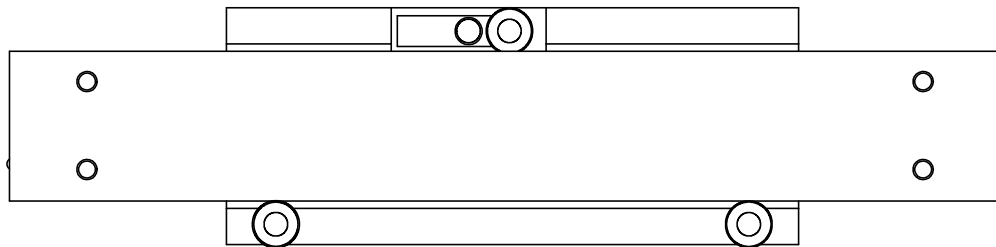
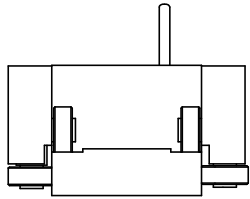
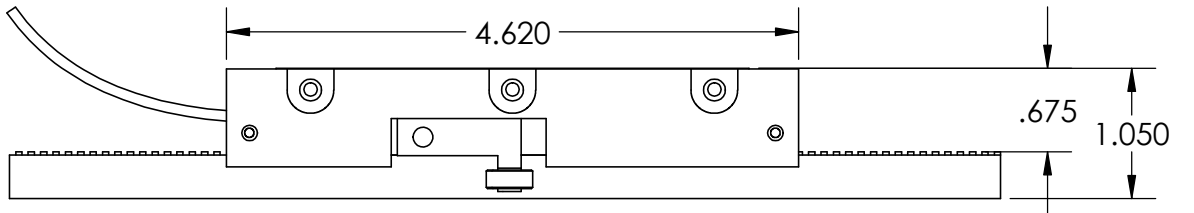
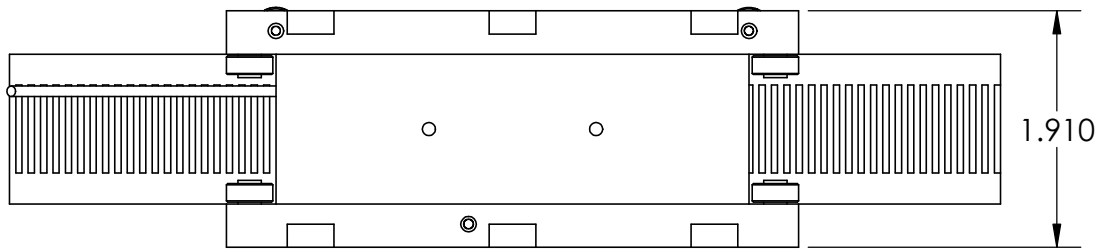

Forcer Mounted on Platen

| | | | |
|-------|---------------------------------|-------|--------|
| TITLE | 4lb Linear Stepper Motor | | |
| DWG # | 10-0611 | REV | --- |
| | | SHEET | 3 of 4 |

LINEAR STEPPER MOTOR SPECIFICATIONS

| | | |
|------------------------|----------------|-----------|
| Motor P/N | LMSS0604-2WW0 | |
| Continuous Force | 4.0 LBS | 17.8 N |
| Rated Current | 3.0 Amp | |
| Resistance/Phase @ 20C | 3.1 ohms | |
| Inductance/Phase @ 20C | 0.50 mH | |
| Motor Phases | 2 | |
| Bearing Type | Roller Bearing | |
| Nominal Airgap | 0.0015" | |
| Motor Mass | 9.6 oz | 272 grams |

| | | | |
|-------|---------------------------------|-------|--------|
| TITLE | 4lb Linear Stepper Motor | | |
| DWG # | 10-0611 | REV | --- |
| | | SHEET | 4 of 4 |