

These drawings and specifications are the property of H2W Technologies, Inc. They are issued in confidence and shall not be reproduced, copied, or used without written permission from H2W Technologies, Inc.

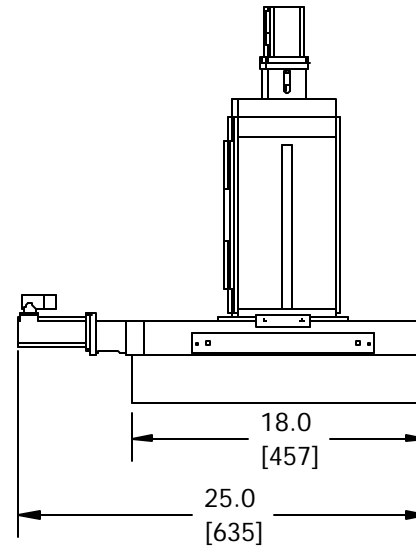

Dual XZ  
Cross Roller  
Stage

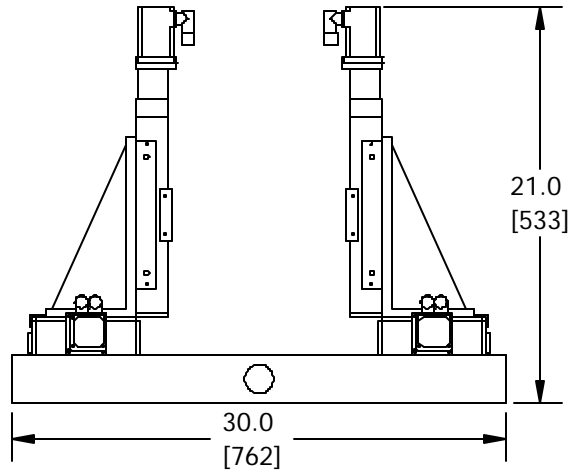
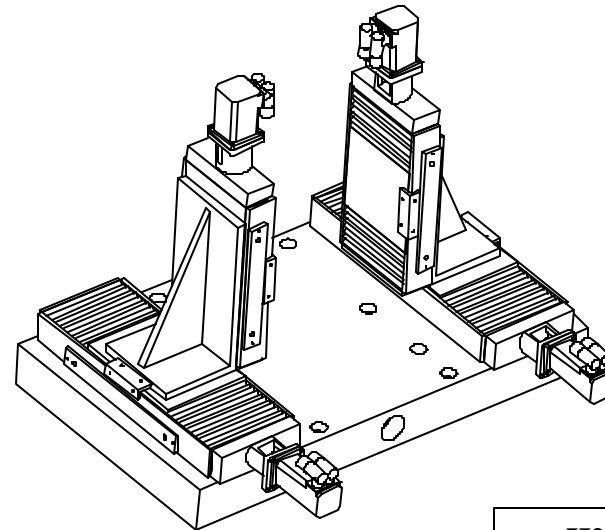
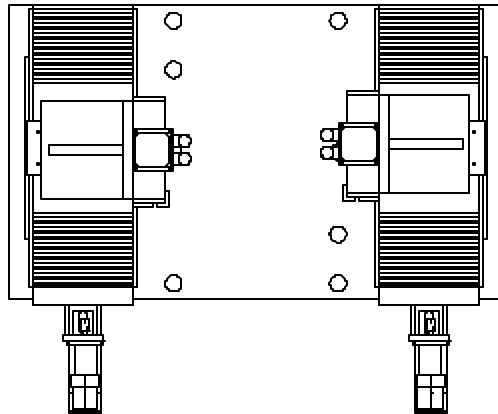

X Stroke = 6" [150mm]  
Z Stroke = 4" [100mm]  
1 Micron Linear Encoders

**H2W Technologies, Inc.**  
28310-C Ave Crocker Valencia, CA 91355 USA  
Tel: (661)-702-9346 Fax: (661)-702-9348  
www.h2wtech.com

UNLESS SPECIFIED OTHERWISE:  
All dimensions are in inches  
Standard Tolerances are as follows  
XXX ±.005 ANGLES ±1°  
XX ±.010 FILLETS AND  
X ±.020 CORNERS .010  
Remove All Burrs and Sharp Edges

MATERIAL				TITLE	
FINISH				Multi-Axis, Gantry System	
DRAWN OOG	DATE 12-3-01	APPROVED FGW	DATE 12-3-01	DWG #	REV
					ECN