

These drawings and specifications are the property of H2W Technologies, Inc. They are issued in confidence and shall not be reproduced, copied, or used without written permission from H2W Technologies, Inc.

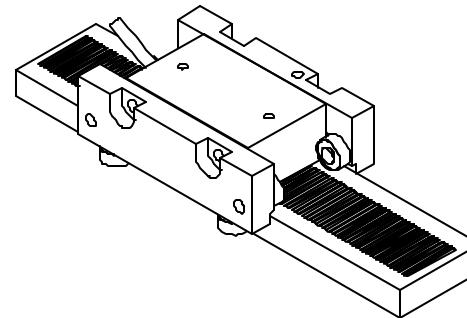
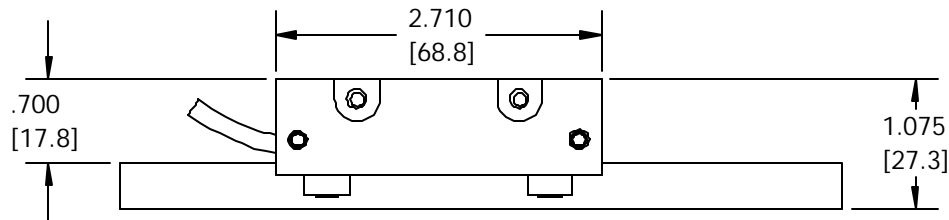
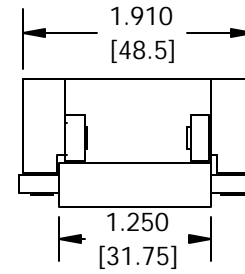
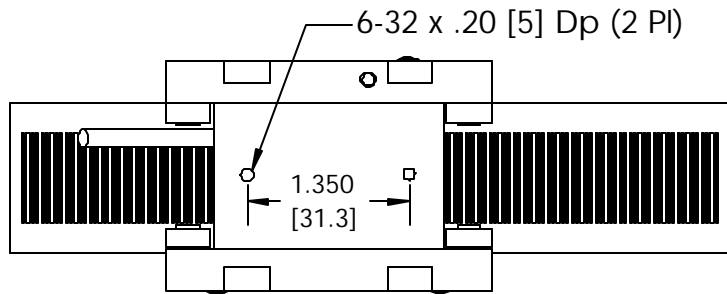

H2W Technologies, Inc.

28310-C Ave Crocker Valencia, CA 91355 USA
 Tel: (661)-702-9346 Fax: (661)-702-9348
 www.h2wtech.com

UNLESS SPECIFIED OTHERWISE: All dimensions are in inches Standard Tolerances are as follows .XXX ±.005 ANGLES ±1° .XX ±.010 FILLETS AND X ±.020 CORNERS .010 Remove All Burrs and Sharp Edges				MATERIAL		TITLE	
				FINISH		2 Lb Stepper	
DRAWN	DATE	APPROVED	DATE	DWG #	REV	ECN	
OOG	12-3-01	FGW	12-3-01				